

Specifications  
**SOT16000**  
Powershift Transmission  
80 to 115 Hp (60 to 85 kW)

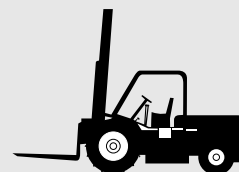

***SPICER OFF-HIGHWAY PRODUCTS***

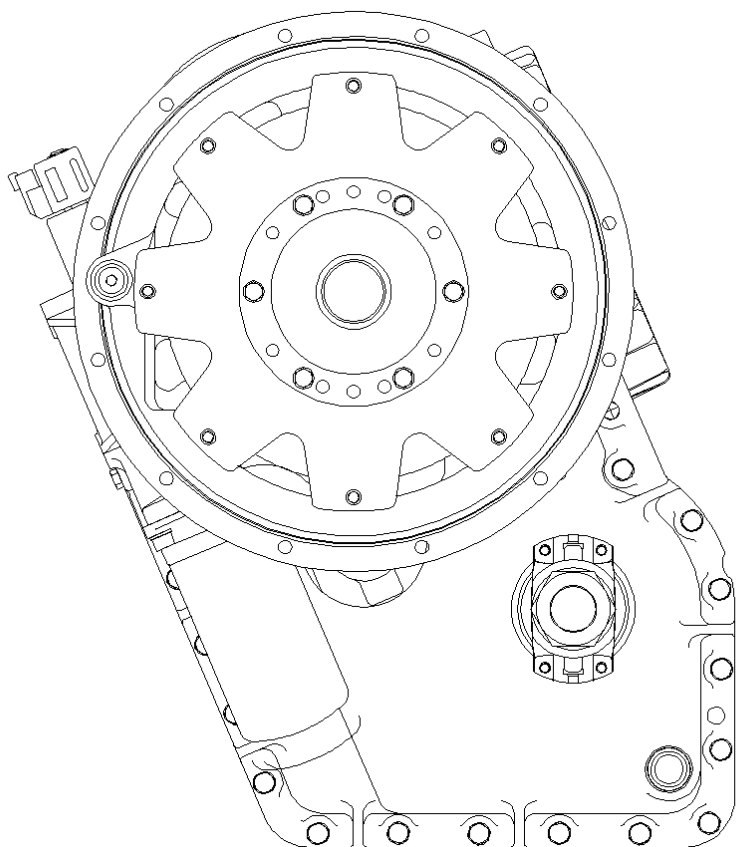

# Complete Flexibility in Mounting & Design

# SOT16000

Mounting configurations are available in upper and lower output and intermediate drop.

## ENGINE MOUNTED

The HR Series is an integral transmission and converter assembly mounted directly to the engine. As a single compact package, it minimizes external piping and eliminates a drive shaft.

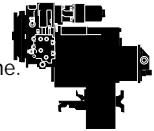

## OPTIONS

Remote filter
205mm (8.1") dropped rear output
Disc parking brake
Front axle disconnect
Electronic gear selector (EGS)
Automatic powershift control (APC)

## CONVERTER

Housing size SAE 3 Standard		
Wheel size 11" 12"		
Types	Stall Ratio	Freewheel
Out Match	2.54	Yes
Out Match	2.60	Yes
Tight Match	2.31	Yes
Lug Match	2.05	Yes
Maximum Input RPM 2600		
<b>SPECIFICATIONS</b>		
Mounting HR		
Configuration ID 309mm (12.16")		
Offset 158mm (6.22")		
Speeds FDW: 4 REV: 2		
Pump Drives Standard SAE "C" 2 or 4 bolt mounting		

## RATIOS

(*)Ratio to upper rear output		
	FDW	REV
1st	4.863:1	4.085:1
2nd	2.571:1	2.160:1
3rd	1.284:1	
4th	0.679:1	
(*) Ratio to lower front & rear output		
	FDW	REV
1st	4.664:1	3.918:1
2nd	2.466:1	2.072:1
3rd	1.232:1	
4th	0.651:1	

## WEIGHT/DIMENSIONS/OIL

Weight (dry)	295 kg (651 lbs)
Max. Length	578.0 mm (22.8")
Max. Width	588.0 mm (23.2")
Max. Height	227.0 mm (8.9")
Oil Capacity	14 l (3.7 US Gallon)



SPICER OFF-HIGHWAY PRODUCTS DIVISION

Ten Briele 3 B-8200 BRUGGE BELGIUM Tel. +32 (0)50 402 541 Fax. +32 (0)50 402 402

ALL APPLICATIONS MUST BE APPROVED BY THE APPLICATION ENGINEERING DEPARTMENT  
SPECIFICATIONS and/or DESIGN ARE SUBJECT TO CHANGE WITHOUT NOTICE OR OBLIGATION